



**Model Name** **MX520 Digital Projector**

**Unique selling point** **Trade Mark**

- \* SmartEco Power Saving technology
- \* 3000AL High Brightness
- \* Up to 6500hours Long lamp life
- \* <0.5W standby mode
- \* Various 3D format for entertainment



<b>Projection System</b>	DLP	
<b>Native Resolution</b>	XGA(1024 x 768)	
<b>Brightness</b>	3000AL	
<b>Contrast Ratio</b>	13000:1	
<b>Display Color</b>	1.07 Billion Colors	
<b>Lens</b>	F2.56-2.8, f=21-23.1mm	
<b>Aspect Ratio</b>	Native 4:3 (5 aspect ratio selectable)	
<b>Throw Ratio</b>	1.86-2.04 ( 53"@ 2m )	
<b>Image Size (Diagonal)</b>	40"-300"	
<b>Zoom Ratio</b>	1.1:1	
<b>Lamp Type</b>	210W	
<b>Lamp(Normal/Economic/SmartEco Mode)*</b>	4500/6000/6500 hours	
<b>Keystone Adjustment</b>	1D, Vertical +/- 40 degrees	
<b>Projection Offset</b>	120% ±5%	
<b>Resolution Support</b>	VGA(640 x 480) to UXGA(1600 x 1200)	
<b>Horizontal Frequency</b>	15~102KHz	
<b>Vertical Scan Rate</b>	23~120Hz	
<b>Compatibility</b>	HDTV Compatibility	480i, 480p, 576i, 576p, 720p, 1080i, 1080p
	Video Compatibility	NTSC, PAL, SECAM
<b>Interface</b>	Computer in (D-sub 15pin)	x 2(Share with component)
	Monitor out (D-sub 15pin)	x 1
	Composite Video in (RCA)	x 1
	S-Video in (Mini DIN 4pin)	x 1
	HDMI	x1
	Audio in (Mini Jack)	x 2
	Audio in (L/R)	x1
	Audio out (Mini Jack)	x 1
	Speaker	2W x 1
	USB (Type mini B)	x1 (Download & page/down)
	RS232 (DB-9pin)	x 1
	IR Receiver	x1 (Front)
<b>Dimensions</b>	Dimensions(W x H x D)	287.3 x 114.4 x 232.6 mm
	Weight	2.4kg(5.28lbs)
<b>Power</b>	Power Supply	AC100 to 240 V, 50 to 60 Hz
	Power Consumption	293W(typical), Standby<0.5W
<b>Audible Noise</b>	33/28 dBA (Normal/Economic mode)	
<b>On-Screen Display Languages</b>	Arabic/Bulgarian/ Croatian/ Czech/ Danish/ Dutch/ English/ Finnish/ French/ German/ Greek/ Hindi/ Hungarian/ Italian/ Indonesian/ Japanese/ Korean/ Norwegian/ Polish/ Portuguese/ Romanian/ Russian/ Simplified Chinese/Spanish/ Swedish/ Turkish/ Thai/ Traditional Chinese (28 Languages)	
<b>Picture Modes</b>	Dynamic/Presentation/sRGB/Cinema/(3D)/User 1/User 2	
<b>Accessories</b>	<b>Standard</b>	<b>Optional</b>
	Lens Cover	Presentation Plus
	Remote Control w/ Battery	Spare Lamp Kit 5JJ6V05.001
	Power Cord (by region)	Ceiling Mount
	User Manual CD	3D Glasses
	Quick Start Guide	Carry bag
	Warranty Card (by region)	
	VGA(D-sub 15pin) Cable	

\*Lamp life results will vary depending on environmental conditions and usage. Actual product's features and specifications are subject to change without notice.

## Distance Chart

## MX520 Digital Projector

Screen size				Projection distance (mm)			Vertical offset (mm)
Diagonal		W (mm)	H (mm)	Min distance	Average	Max distance	
Inch	mm			(max. zoom)		(min. zoom)	
30	762	610	457	1132	1189	1245	46
40	1016	813	610	1509	1585	1660	61
50	1270	1016	762	1887	1981	2075	76
60	1524	1219	914	2264	2377	2491	91
80	2032	1626	1219	3019	3170	3321	122
100	2540	2032	1524	3774	3962	4151	152
120	3048	2438	1829	4528	4755	4981	183
150	3810	3048	2286	5660	5943	6226	229
200	5080	4064	3048	7547	7925	8302	305
220	5588	4470	3353	8302	8717	9132	335
250	6350	5080	3810	9434	9906	10377	381
300	7620	6096	4572	11321	11887	12453	457

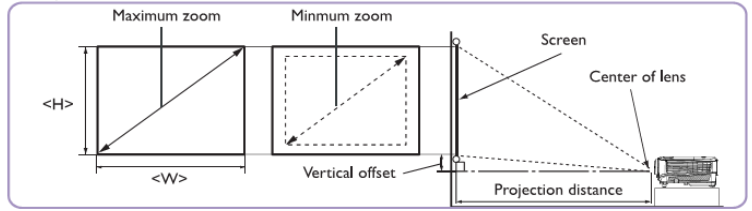

## Wall mount/Ceiling mount Chart

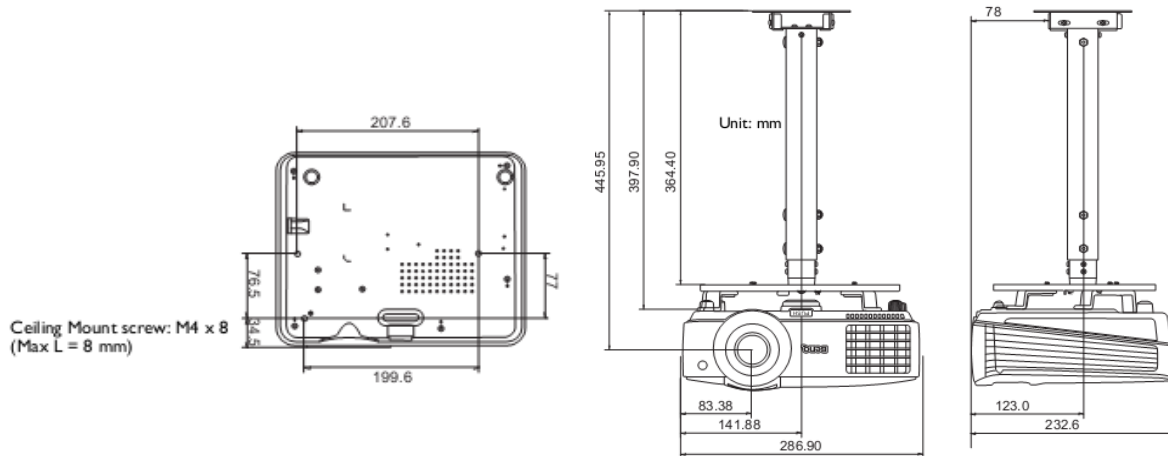

## Dimension

