



# MITSUBISHI ELECTRIC

## MULTIMEDIA DATA/VIDEO PROJECTORS

*Changes for the Better*



*In the Boardroom or Classroom...  
Add life to your presentations*

**NEW**  
Mobile  
XGA  
Projector

# EX200U

**POINT 1** *Light & compact body*

*A light 5.3lb, 2300lm brightness*

The EX200U weighs in at a light 5.3lb for excellent portability, and offers an impressive projection brightness of 2300lm. Whether used in a meeting room or classroom, clear images are reproduced—even in ambient light.

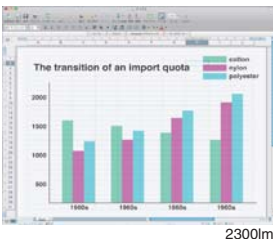
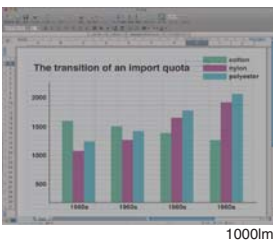

**POINT 2** *Usability*

*Wall Screen*

Projects natural color images not only onto white boards or screens, but light-yellow, blue, light-green or pink walls as well — turning nearly any wall into a projection surface.

*Direct Power Off*

The EX200U features a direct power off function that immediately cuts all power, eliminating the annoying power-down time required before unplugging the projector. When the presentation is over, simply turn off the power, disconnect the projector, and you're ready to go. A must-have feature for people that require mobility and have busy schedules.

*Top-loading lamp*

The projection lamp is installed in the upper section of the main body. Whether sitting on a shelf or suspended from the ceiling, lamp replacement is simple and easy<sup>\*1</sup>, and there's never a need to move the whole projector.

<sup>\*1</sup>: A lamp replacement attachment is included to prevent the lamp from being dropped during replacement.



**POINT 3** *Ecological & Cost-efficient*

*Long 4,000hr<sup>\*2</sup> Lamp Life*

By increasing the estimated lamp life, we've added the advantages of lower maintenance and reduced operating cost.

*Lamp Replacement Frequency<sup>\*3</sup>*

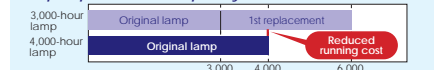

<sup>\*2</sup>: When used in low lamp mode. Maximum lamp life in standard mode use is 3,000 hours.

<sup>\*3</sup>: Lamp life refers to the average time required for brightness to be reduced by half, and not the time specified in the warranty. Lamp service life may vary widely depending on the environment and conditions, and whether or not cleaning and other maintenance procedures are followed.

*Stand-by Mode under 1W*

Stand-by mode power consumption is less than 1W, offering increased energy savings and further contributing to environmental preservation.

**NEW**



# EX200U

Mobile XGA Projector

- Brilliant Color™
- Wall Screen
- Password Lock
- Direct Power Off
- Long-life Lamp
- Low Standby Power
- Picture Performance
- User Friendly
- Top Loading Lamp
- Closed Caption
- Low Fan Noise

## Other Features

- Superior Color Performance  
**New BrilliantColor™ (6segment color wheel) Adopted**  
\*BrilliantColor is a trademark of Texas Instruments.
- For worldwide business presentation  
**18 Languages OSD**
- Automatic Subtitle Function  
**Closed Caption (cc) Capable**
- Enhanced Terminal  
**Dual RGB Input Terminal**

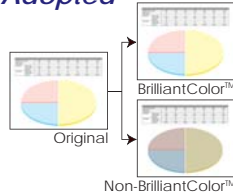

## Input and Output Terminals

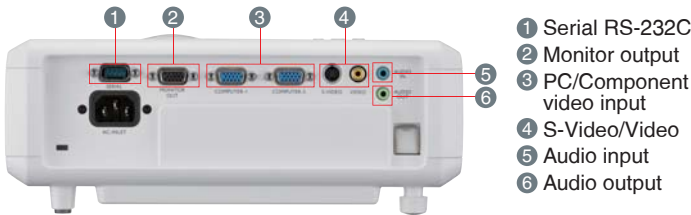

## Dimensions

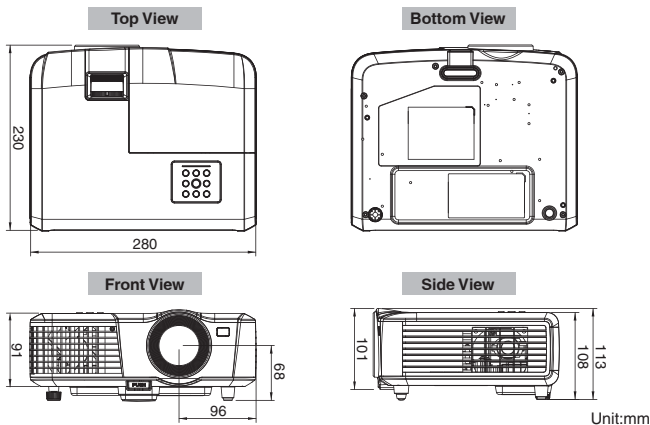

## Specifications

Model	EX200U
Display Technology	0.55" 1-Chip DMD
Resolution	1024 x 768 (Total 786,432 pixels)
Brightness	2300lm
Contrast Ratio	1250 : 1
Projection lens	f=2.64 ~2.75 mm, F=21.13~23.0, (149"-165"@100")
Offset axis	9:-1 Hd = 7.5" up @ 100"
Picture Size	40" - 300"
Throw Ratio	1.9 - 2.1
Est. Lamp Life Rating	4000 hours* (Low Mode) 3000 hours (Standard Mode)
PC Compatibility	Expanded: 640 x 400, Compressed: 1600 x 1200, True: 1024 x 768, Sync on Green available
Video Compatibility	NTSC / NTSC 4.43 / PAL (including PAL-M, N) / SECAM / PAL-60 Component Video: 480i/p (525i/p), 576i/p (625i/p), 720p (750p), 1080i (1125i 60Hz), 1080i (1125i 50Hz)
Input Terminals	RGB: mini D-sub 15pin x 2 RCA x 1 + S-VIDEO x 1 Audio: Stereo mini jack (ø3.5mm) x 1
Output Terminals	RGB: mini D-sub 15pin x 1 Audio: Stereo mini jack (ø3.5mm) x 1
Communication Terminal	RS-232C" D-Sub 9pin x 1
Audio Speaker	2W Mono
Dimensions (W x H x D)	11.0" x 3.6" x 9.1"
Weight	5.3lbs
Power Requirements	AC 100-240V, 50/60Hz
Optional Lamp	VLT-EX240LP
Included Accessories	User-Manual (CD-ROM), Card Remote Control (w/ battery), Power Cord, VGA(D-sub) Cable, Quick Startup Guide & Safety Manual
Warranty	3-Years of Parts/Labor, 3-Years of Express Replacement Assistance (ERA), 1-year or 500 hours lamp warranty (whichever comes first)

- Compliance with ISO21118-2005
- All brand names and product names are trademarks, registered trademarks or trade names of their respective holders.
- Lamp life specification is an estimate based on information provided by the lamp manufacturer and is not the duration of the warranty. Lamp will shut-off automatically when usage reaches the specified estimated maximum lamp hours.

## Screen size and Projection distance

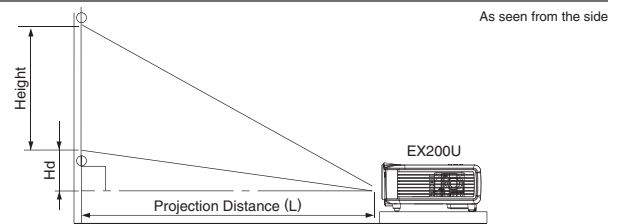

Screen size chart (4:3 aspect ratio)

Diagonal Size	Screen		Distance from screen (L)				Height projected image (Hd)				
	Width (W)	Height (H)	Shortest (Wide)	Longest (Tele)	inch	m	inch	cm			
40	102	32	81	24	61	60	1.5	66	1.7	2	6
60	152	48	122	36	91	90	2.3	99	2.5	4	9
80	203	64	163	48	122	120	3.0	132	3.4	5	12
100	254	80	203	60	152	150	3.8	165	4.2	6	15
150	381	120	305	90	229	225	5.7	247	6.3	9	23
200	508	160	406	120	305	300	7.6	330	8.4	12	30
250	635	200	508	150	381	375	9.5	412	10.5	15	38
300	762	240	610	180	457	450	11.4	-	-	18	46

The above numbers are approximate, and may be slightly different from the actual measurements.

Screen size chart (16:9 aspect ratio)

Diagonal Size	Screen		Distance from screen (L)				Height projected image (Hd)				
	Width (W)	Height (H)	Shortest (Wide)	Longest (Tele)	inch	m	inch	cm			
40	102	35	89	20	50	66	1.7	73	1.9	6	15
60	152	52	133	29	75	99	2.5	109	2.8	9	22
80	203	70	177	39	100	132	3.4	146	3.7	12	30
100	254	87	221	49	125	166	4.2	182	4.6	15	37
150	381	131	332	74	187	248	6.3	273	6.9	22	56
200	508	174	443	98	249	331	8.4	364	9.3	29	75
250	635	218	553	123	311	414	10.5	455	11.6	37	93
275	699	240	609	135	342	455	11.6	-	-	40	103

The above numbers are approximate, and may be slightly different from the actual measurements.

**MITSUBISHI DIGITAL ELECTRONICS AMERICA, INC.**  
 Presentation Products Division  
 Phone: 888.307.0349  
 www.mitsubishi-presentations.com

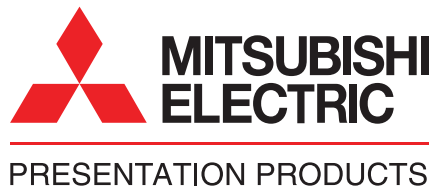

**MITSUBISHI ELECTRIC SALES CANADA, INC.**  
 Display & Imaging Solutions Division  
 Phone: 905.475.7728  
 www.mitsubishielectric.ca