

CP-DW10N

INNOVATE
The Future of Projection



SHORT THROW WXGA LCD PROJECTOR

Project large, bright images in limited space with Hitachi's new range of short throw projectors. Perfect for small and medium meeting rooms, the CP-DW10N WXGA network projector can deliver an impressive 80" image from less than a metre away (from lens to screen). Expect no less from the experts in short throw projection.

Performance

- WXGA resolution (1280 x 800)
- 2000 ANSI Lumens
- 80" screen from 86.2cm[†]
- Quick On and Auto Off
- Low noise level - 28dB in Eco Mode
- Daytime Mode
- HDMI connection
- Anti Theft features:
 - PIN-Lock
 - MyScreen Password
 - Keypad Lock
 - Kensington slot
 - Transition Detector

Cost of ownership

- Extended filter life of 4000 hours with Hybrid Filter
- Long lamp life - 4000 hours (Eco Mode)*
- No additional filter cleaning costs
- Easy set up and installation
- Power saving mode
- Virtually maintenance free

Advanced Network Features

- Full connectivity including 1 x RJ-45
- Configure and control projector via network with a web browser
- Projector management via SNMP
- AMX Device Discovery
- Messenger
- PJ Link™
- Network Bridge

Environment

- The extended Hybrid Filter life means reduced electronic waste and reduced maintenance visits, resulting in an overall reduction in carbon footprint
- Paint-free casing
- Recyclable carton boxes
- Reduced power consumption - only 1W in Standby Mode

Hitachi have formulated an "Environmental Vision" to contribute towards building a sustainable society through business and product development.

Our goal is to develop life-enhancing technology that will contribute to and realise a truly sustainable society for current and future generations.

[†]from lens to screen



www.hitachidigitalmedia.com

HITACHI
Inspire the Next

CP-DW10N

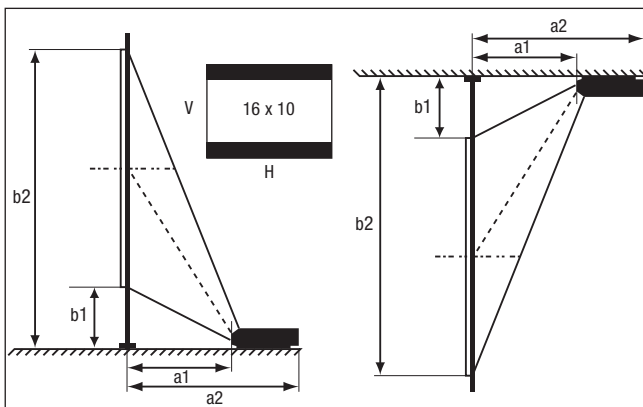
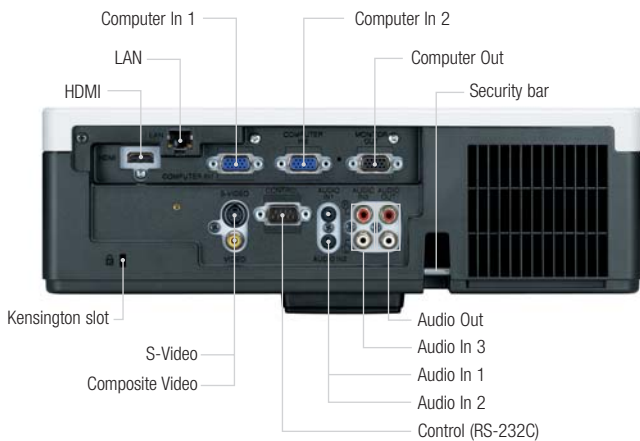

Throw distance (from the top of the lens)

Screen size (diagonal)	H x V		a1	a2	b1	b2
	(m)	(m)				
60" (1.5m)	1.3	0.8	0.634	0.921	0.264	1.072
70" (1.8m)	1.5	0.9	0.748	1.035	0.298	1.240
80" (2.0m)	1.7	1.1	0.862	1.149	0.331	1.408
90" (2.3m)	1.9	1.2	0.975	1.262	0.364	1.575
100" (2.5m)	2.2	1.3	1.089	1.376	0.397	1.743

OPTICAL

LCD Panel		0.59" P-Si TFT x 3
Resolution		WXGA
Brightness	Normal Mode	2000 ANSI Lumens
	Eco Mode	1500 ANSI Lumens
Contrast ratio		400:1
Lens		Manual focus
Lamp wattage		180W UHB
Lamp life		3000 hours (Normal Mode)/4000 hours (Eco Mode)*
Diagonal display size		60~100" (80"@86cm)
Number of colours		8 Bit/colour, 16.7M colours
Keystone Correction		Fixed, 5.1:-1 upward shift
Distance to Width Ratio		0.5:1 (fixed)

COMPATIBILITY

Computer compatibility	IBM Compatible VGA, SVGA, XGA, WXGA, SXGA, SXGA+, UXGA Compressed, MAC 16"
Composite/S-Video	NTSC/PAL/SECAM/PAL-M/PAL-N/NTSC4.43/PAL60
Component Video	525i(480i), 525p(480p), 625i(576i), 1125i(1080i@50/60), 750p(720p@50/60), 1125p(1080p@50/60)
HDMI Video	Signal: 525i(480i), 525p(480p), 625i(576i), 1125i(1080i@50/60), 750p(720p@50/60), 1125p(1080p@50/60)
Plug & Play	DDC2B (RGB1 Input)

FEATURES

Speaker	10W Mono
Basic functions	Freeze, Magnifying, Blank, Auto adjustment, Auto Signal Search
Picture adjustments	Digital zoom x 1.35, Equalizing Gamma Correction, 2-3 pull down, Progressive Scan, Noise Reduction
Digital keystone	Manual V keystone ±6 degrees
Advanced features	MyScreen, My Memory, My Button, My Text, My Source, Blackboard/Whiteboard mode, Daytime Mode, Input Source Naming (English), Resolution setting, Template, Closed Caption (for NTSC only), Audio Pass Through
Outward	Easy lamp replace from top, Air filter slides towards front side or top
Power on & off	Quick Power On, Direct On, Auto Off
Security systems	Security bar, PIN-Lock, MyScreen Password, Keypad-Lock, Kensington slot, Transition detector, My Text, Security label
Network	Configure and control projector via web browser, receive alerts via e-mail, projector management via SNMP, Scheduling, My Image, Command Control via network, Messenger, AMX Device Discovery, PJ Link™, Network Bridge
OSD languages	English, French, German, Spanish, Italian, Norwegian, Dutch, Japanese, Portuguese, Simplified Chinese, Traditional Chinese, Korean, Swedish, Russian, Finnish, Polish, Turkey, Arabian, Persian, Czech, Danish, Hungarian, Romanian, Slovenian, Croatian, Greek, Lithuanian, Estonian, Latvian, Thai, Portuguese (Brazil)

CONNECTIONS

Digital input	1 x HDMI
Computer input	2 x 15-pin Mini D-sub
Computer output	1 x 15-pin Mini D-sub
Video input	2 x Component D-sub (shared with analogue RGB)
	1 x RCA for composite
	1 x Mini-DIN for S-Video
Audio input	2 x Stereo Mini Jack
	1 x pair RCA (L/R) (Selectable on OSD)
Audio output	1 x pair RCA (L/R)
Control	1 x 9-pin D-sub for RS-232C control
Network	1 x RJ-45

POWER

Power supply	100-120V/220-240V, auto switching
Power Consumption/Standby	270W/<1W

PHYSICAL

Dimensions (W x H x D)	333 x 103 x 303mm (excluding feet and extrusions)
Weight	3.7Kg
Noise level	28dB (Eco Mode)/36dB (Normal Mode)
Air filter	Hybrid

MISCELLANEOUS

Lamp indicator light, Power light, Ceiling mount image, Rear projection image, Serial number label on side

CERTIFICATION

EN60950-1 (Low voltage directive) CE Marking EN61000-3-2, EN61000-3-3, EN55022, EN55024 (EMC directive), GOST-R

ACCESSORIES SUPPLIED

Remote control with batteries, Computer cable, Power cord, Lens cap, Security label, User manual (detail & concise)

OPTIONAL ACCESSORIES

Replacement lamp	DT01091
Laser pointer remote control	HL02483
Cable cover	CCAW100

WARRANTY

Projector warranty	3 Years
Lamp warranty	6 Months**



HITACHI DIGITAL MEDIA, Hitachi Europe Ltd, Whitebrook Park, Lower Cookham Road, Maidenhead, Berkshire SL6 8YA UNITED KINGDOM
Tel: +44 (0)1628 585 000 Fax: +44 (0)1628 585 500 www.hitachidigitalmedia.com

*The stated lamp life refers to the average life expected in ideal operating conditions with usage in accordance with the manual. The majority of, but not all lamps should achieve this figure. **Where a lamp fails within warranty and a replacement lamp is taken, the warranty for the replacement lamp will be a maximum of 6 months (dependent on warranty hours stated). The "HD ready" Logo is a trademark of EICTA. HDMI, the HDMI logo and High-Definition Multimedia Interface are trademarks or registered trademarks of HDMI Licensing LLC. The specification above and photography is for reference only and may be subject to change.

